



Shenzhen Huaxia Testing Technology Co., Ltd.

1F., Block A of Tongsheng Technology Building, Huahui Road, Dalang Street, Longhua District, Shenzhen, China

Telephone: +86-755-26648640

Fax: +86-755-26648637

Website: www.cqa-cert.com

Report Template Version: V05

Report Template Revision Date: 2021-11-03

TEST REPORT

Report No.: CQASZ20250300702E-02
Applicant: Shenzhen PioCreat 3d Technology Co., Ltd.
Address of Applicant: 3rd Floor, Building 1, No. 156 Huawang Road, Langkou Community, Dalang Street, Longhua District, Shenzhen, China
Equipment Under Test (EUT):
EUT Name: 3D Printer
Model No.: HALOT-X1, HALOT-X1 Combo
Test Model No.: HALOT-X1
Brand Name: N/A
Standards: ETSI EN 301 489-1 V2.2.3 (2019-11)
ETSI EN 301 489-17 V3.2.4 (2020-09)
Date of Receipt: 2025-03-31
Date of Test: 2025-03-31 to 2025-05-15
Date of Issue: 2025-05-30
Test Result: **PASS***

*In the configuration tested, the EUT complied with the standards specified above

Tested By: *Lewis Zhou*
(Lewis Zhou)

Reviewed By: *Timo Lei*
(Timo Lei)

Approved By: *Jack Ai*
(Jack Ai)



1 Version

Revision History of Report

Report No.	Version	Description	Issue Date
CQASZ20250300702E-02	Rev.01	Initial report	2025-05-30

2 Test Summary

Electromagnetic Compatibility (EMC) Part				
Electromagnetic Interference (EMI)				
Test	Test Requirement	Test Method	Limit	Result
Radiated Emission	ETSI EN 301 489-17 V3.2.4 (2020-09) Clause 7.1	EN 301 489-1 V2.2.0 (2017-03) Clause 8.2	Clause 8.2.3	PASS
Conducted Emission (DC port)	ETSI EN 301 489-17 V3.2.4 (2020-09) Clause 7.1	EN 301 489-1 V2.2.0 (2017-03) Clause 8.3	Clause 8.3.3	N/A ¹⁾
Conducted Emission (AC port)	ETSI EN 301 489-17 V3.2.4 (2020-09) Clause 7.1	EN 301 489-1 V2.2.0 (2017-03) Clause 8.4	Clause 8.4.3	PASS
Harmonic Emission on AC, 50Hz to 2kHz	ETSI EN 301 489-17 V3.2.4 (2020-09) Clause 7.1	EN 301 489-1 V2.2.0 (2017-03) Clause 8.5	Clause 8.5	PASS
Flicker Emission on AC	ETSI EN 301 489-17 V3.2.4 (2020-09) Clause 7.1	EN 301 489-1 V2.2.0 (2017-03) Clause 8.6	Clause 8.6	PASS
Conducted Emission (telecommunication port)	ETSI EN 301 489-17 V3.2.4 (2020-09) Clause 7.1	EN 301 489-1 V2.2.0 (2017-03) Clause 8.7	Clause 8.7.3	N/A
Electromagnetic Susceptibility(EMS)				
ESD (Electrostatic Discharge)	ETSI EN 301 489-17 V3.2.4 (2020-09) Clause 7.2	EN 301 489-1 V2.2.0 (2017-03) Clause 9.3	Clause 9.3.3	PASS
Radiated Immunity, 80MHz to 6 GHz	ETSI EN 301 489-17 V3.2.4 (2020-09) Clause 7.2	EN 301 489-1 V2.2.0 (2017-03) Clause 9.2	Clause 9.2.3	PASS
EFT (Electrical Fast Transients)	ETSI EN 301 489-17 V3.2.4 (2020-09) Clause 7.2	EN 301 489-1 V2.2.0 (2017-03) Clause 9.4	Clause 9.4.3	PASS
Surge Immunity	ETSI EN 301 489-17 V3.2.4 (2020-09) Clause 7.2	EN 301 489-1 V2.2.0 (2017-03) Clause 9.8	Clause 9.8.3	PASS
Injected Currents 150kHz to 80MHz	ETSI EN 301 489-17 V3.2.4 (2020-09) Clause 7.2	EN 301 489-1 V2.2.0 (2017-03) Clause 9.5	Clause 9.5.3	PASS
Voltage Dips and Interruptions	ETSI EN 301 489-17 V3.2.4 (2020-09) Clause 7.2	EN 301 489-1 V2.2.0 (2017-03) Clause 9.7	Clause 9.7.3	PASS
Transients and Surges in the Vehicular Environment	ETSI EN 301 489-17 V3.2.4 (2020-09) Clause 7.2	EN 301 489-1 V2.2.0 (2017-03) Clause 9.6	Clause 9.6.3	N/A ¹⁾

Remark:

N/A¹⁾: Because this test EUT rated power is less than 75W.

Tx: In this whole report Tx (or tx) means Transmitter.

Rx: In this whole report Rx (or rx) means Receiver.

RF: In this whole report RF means Radiated Frequency.

CH: In this whole report CH means channel.

Volt: In this whole report Volt means Voltage.

Temp: In this whole report Temp means Temperature.

Humid: In this whole report Humid means humidity.

Press: In this whole report Press means Pressure.

N/A: In this whole report not application.

3 Contents

	Page
1 VERSION	2
2 TEST SUMMARY	3
3 CONTENTS	5
4 GENERAL INFORMATION	6
4.1 CLIENT INFORMATION	6
4.2 GENERAL DESCRIPTION OF EUT	6
4.3 PRODUCT SPECIFICATION SUBJECTIVE TO THIS STANDARD	6
4.4 DESCRIPTION OF SUPPORT UNITS	7
4.5 TEST LOCATION	7
4.6 DEVIATION FROM STANDARDS	7
4.7 ABNORMALITIES FROM STANDARD CONDITIONS	7
4.8 OTHER INFORMATION REQUESTED BY THE CUSTOMER	7
4.9 MONITORING OF EUT FOR THE IMMUNITY TEST	7
4.10 MEASUREMENT UNCERTAINTY (95% CONFIDENCE LEVELS, K=2)	8
5 EQUIPMENT LIST	9
6 EMC REQUIREMENTS SPECIFICATION IN EN 301 489-17	11
6.1 EMI (EMISSION)	11
6.1.1 <i>Radiated Emission</i>	11
6.1.2 <i>Conducted Emission</i>	16
6.1.3 <i>Harmonics</i>	19
6.1.4 <i>Flicker</i>	20
6.2 EMS (IMMUNITY)	22
6.2.1 <i>Radiated Immunity</i>	23
6.2.2 <i>ESD</i>	25
6.2.3 <i>RF Common Mode 0.15MHz to 80MHz</i>	27
6.2.4 <i>Electrical Fast Transients (EFT)</i>	29
6.2.5 <i>Surge</i>	31
6.2.6 <i>Voltage Dips and Interruptions</i>	33
APPENDIX 1 PHOTOGRAPHS OF TEST SETUP	34
APPENDIX 2 PHOTOGRAPHS OF EUT	37

4 General Information

4.1 Client Information

Applicant:	Shenzhen PioCreat 3d Technology Co., Ltd.
Address of Applicant:	3rd Floor, Building 1, No. 156 Huawang Road, Langkou Community, Dalang Street, Longhua District, Shenzhen, China
Manufacturer:	Shenzhen PioCreat 3d Technology Co., Ltd.
Address of Manufacturer:	3rd Floor, Building 1, No. 156 Huawang Road, Langkou Community, Dalang Street, Longhua District, Shenzhen, China
Factory:	Shenzhen PioCreat 3d Technology Co., Ltd.
Address of Factory:	3rd Floor, Building 1, No. 156 Huawang Road, Langkou Community, Dalang Street, Longhua District, Shenzhen, China

4.2 General Description of EUT

Product Name:	3D Printer
Model No.:	HALOT-X1,HALOT-X1 Combo
Test Model No.:	HALOT-X1
Trade Mark:	N/A
EUT Supports Radios application:	Bluetooth: 2402-2480MHz
EUT Power Supply:	AC100-120V~,200-240V.50-60Hz, 350W

4.3 Product Specification subjective to this standard

Radio function:	Bluetooth
Software Version:	V1.0
Hardware Version:	V1.2
Test Mode:	
wireless mode:	Keep the EUT exchange data with other device.

4.4 Description of Support Units

The EUT has been tested with associated equipment below.

1) support equipment

Description	Manufacturer	Model No.	Certification	Supplied by
Phone	Apple	iphone5c	/	CQA

2) Cable

Cable No.	Description	Manufacturer	Cable Type/Length	Supplied by
/	/	/	/	/

4.5 Test Location

Other than radiated immunity, all tests were performed at:

Shenzhen Huaxia Testing Technology Co., Ltd.

1F., Block A of Tongsheng Technology Building, Huahui Road, Dalang Street, Longhua District, Shenzhen, China

4.6 Deviation from Standards

None.

4.7 Abnormalities from Standard Conditions

None.

4.8 Other Information Requested by the Customer

None.

4.9 Monitoring of EUT for the Immunity Test

Visual: Monitor display.

Audio: N/A.

4.10 Measurement Uncertainty (95% confidence levels, k=2)

No.	Item	Measurement Uncertainty
1	Conduction emission	3.74dB (9kHz to 150kHz)
		3.34dB (150kHz to 30MHz)
2	Radiated emission	5.12dB (30MHz-1GHz)
		4.60dB (1GHz-6GHz)
3	Radiated Immunity	1.61dB
4	Conducted Immunity	0.92dB
5	Temperature test	0.8°C
6	Humidity test	2.0%
7	DC power test	0.5 %

5 Equipment List

Conducted Emissions (150kHz-30MHz)					
Equipment	Manufacturer	Model No	Inventory No.	Cal Date	Cal Due Date
EMI Test Receiver	R&S	ESPI3	CQA-013	2024/9/2	2025/9/1
LISN	R&S	ENV216	CQA-003	2024/9/2	2025/9/1
Coaxial cable (9KHz~300MHz)	CQA	N/A	C021	2024/9/2	2025/9/1

Radiated Emissions					
Equipment	Manufacturer	Model No	Inventory No.	Cal Date	Cal Due Date
Loop antenna	SCHWARZBECK	FMZB 1516	CQA-060	2023/9/8	2026/9/7
Horn Antenna	R&S	BBHA 9170	CQA-088	2023/11/01	2026/10/31
Horn Antenna	R&S	HF906	CQA-012	2023/11/01	2026/10/31
Bilog Antenna	R&S	HL562	CQA-011	2023/9/7	2026/9/6
EMI Test Receiver	R&S	ESR7	CQA-005	2024/9/2	2025/9/1
Spectrum analyzer	R&S	FSU26	CQA-038	2024/9/2	2025/9/1
Preamplifier	MITEQ	AMF-6D- 02001800- 29-20P	CQA-036	2024/9/2	2025/9/1
Coaxial cable (1GHz~40GHz)	CQA	N/A	C007	2024/9/2	2025/9/1
Coaxial cable (9KHz~1GHz)	CQA	N/A	C013	2024/9/2	2025/9/1

Harmonic Current & Voltage Fluctuation and Flicker					
Equipment	Manufacturer	Model No	Inventory No.	Cal Date	Cal Due Date
Harmonic And Flicker Analyzer	CI	PACS-3	CQA-021	2024/9/2	2025/9/1
AC Power Supply	CI	5001 ix	CQA-073	2024/9/2	2025/9/1

Electrostatic Discharge					
Equipment	Manufacturer	Model No	Inventory No.	Cal Date	Cal Due Date
ESD Simulator	EM TEST	DITO	CQA-001	2024/9/2	2025/9/1

Electrical Fast Transients/Burst & Surge & Voltage Dips and Interruptions at Power Port					
Equipment	Manufacturer	Model No	Inventory No.	Cal Date	Cal Due Date
EMS test system	HTEC	ECOMPACT 7	CQA-002	2024/9/2	2025/9/1
Communications surge generator	HTEC	HTSG 70	CQA-063	2024/9/2	2025/9/1
Capacitive Coupling Clamp	HTC	H3C	CQA-018	2024/9/2	2025/9/1

Conducted Immunity (150kHz-80MHz)					
Equipment	Manufacturer	Model No	Inventory No.	Cal Date	Cal Due Date
RF-Generator	EM TEST	CWS 500	CQA-016	2024/9/2	2025/9/1
6db Attenuator	EM TEST	ATT6/75	CQA-049	2024/9/2	2025/9/1
CDN	SCHWARZBECK	CDN M2/M3PE	CQA-050	2024/9/2	2025/9/1

Radiated Immunity (80MHz-6GHz)					
Equipment	Manufacturer	Model No	Inventory No.	Cal Date	Cal Due Date
Full anechoic chamber	Cheng Yu	966	CQA-009	2024/9/2	2025/9/1
Spectrum analyzer	R&S	FSV40	CQA-075	2024/9/2	2025/9/1
Power amplifier	MILMEGA	AS0860- 75/45	CQA-085	2024/9/2	2025/9/1
Power amplifier	AR	150A220M6	CQA-086	2024/9/2	2025/9/1
antenna	AR	ATH800M5G A	CQA-087	2024/9/2	2025/9/1
Signal generator	R&S	SME06	CQA-024	2024/9/2	2025/9/1
Power meter	R&S	NRVD	CQA-029	2024/9/2	2025/9/1
shielding box	Yuanguai	YG990A	CQA-099	2024/9/2	2025/9/1

6 EMC Requirements Specification in EN 301 489-17

6.1 EMI (Emission)

6.1.1 Radiated Emission

Test Requirement: EN 301 489-17

Test Method: EN 301 489-1 Clause 8.2.2

EUT Operation:

Ambient: Temp.: 25.5°C

Humid.: 53%

Press.: 1009 mbar

Test mode: wireless mode

Receive Setup:

Frequency range (MHz)	Detector	RBW	VBW
30-1000	Quasi-peak	120kHz	300kHz
Above 1000	Peak	1MHz	3MHz

Limit:

Frequency	Limit(@3m)	Detector
30MHz-230MHz	40dB μ V/m	QP
230MHz-1GHz	47dB μ V/m	QP
1GHz-3GHz	50dB μ V/m	Average
	70dB μ V/m	PK
3GHz-6GHz	54dB μ V/m	Average
	74dB μ V/m	PK

Test Setup:

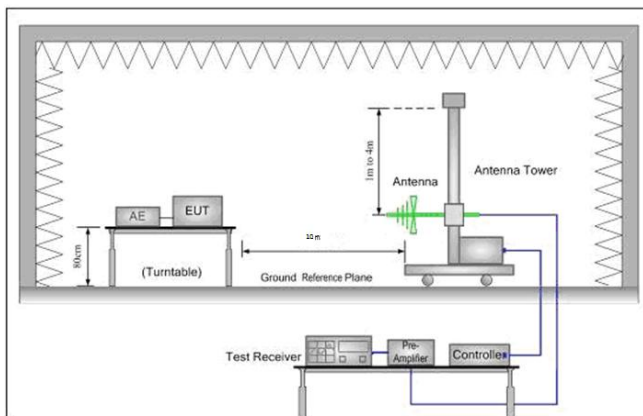

Figure 1. 30MHz to 1GHz

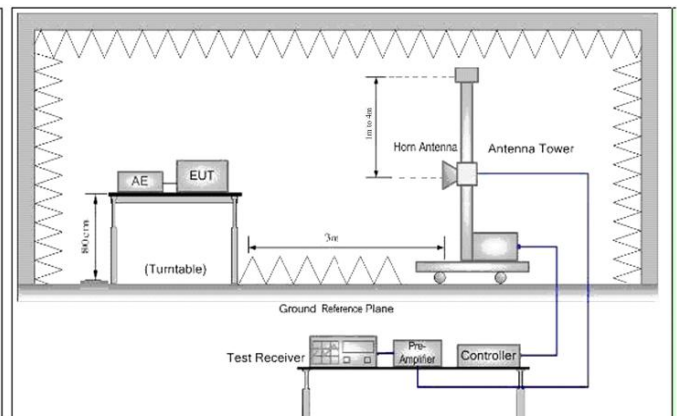

Figure 2. Above 1 GHz

Test Procedure:

- From 30 MHz to 1GHz test procedure as below:
 - The radiated emissions were tested in a semi-anechoic chamber.
 - The EUT is placed on a turntable, which is 0.8m above ground plane.
 - The turntable shall be rotated for 360 degrees to determine the position of maximum emission level.
 - EUT is set 3m away from the receiving antenna, which is moved from 1m to 4m to find out the maximum emissions.
 - Maximum procedure was performed on the six highest emissions to ensure EUT compliance.
 - And also each emission was to be maximized by changing the polarization of receiving antenna both horizontal and vertical.
 - Repeat above procedures until the measurements for all frequencies are complete.

2. Above 1GHz test procedure as below:

- 1) Different between above is the test site, change from Semi- Anechoic Chamber to fully Anechoic Chamber, EUT is set 3m away from the receiving antenna

Equipment Used: Refer to section 5 for details.

Test result: PASS

Measurement Data:

Below 1GHz:

Vertical

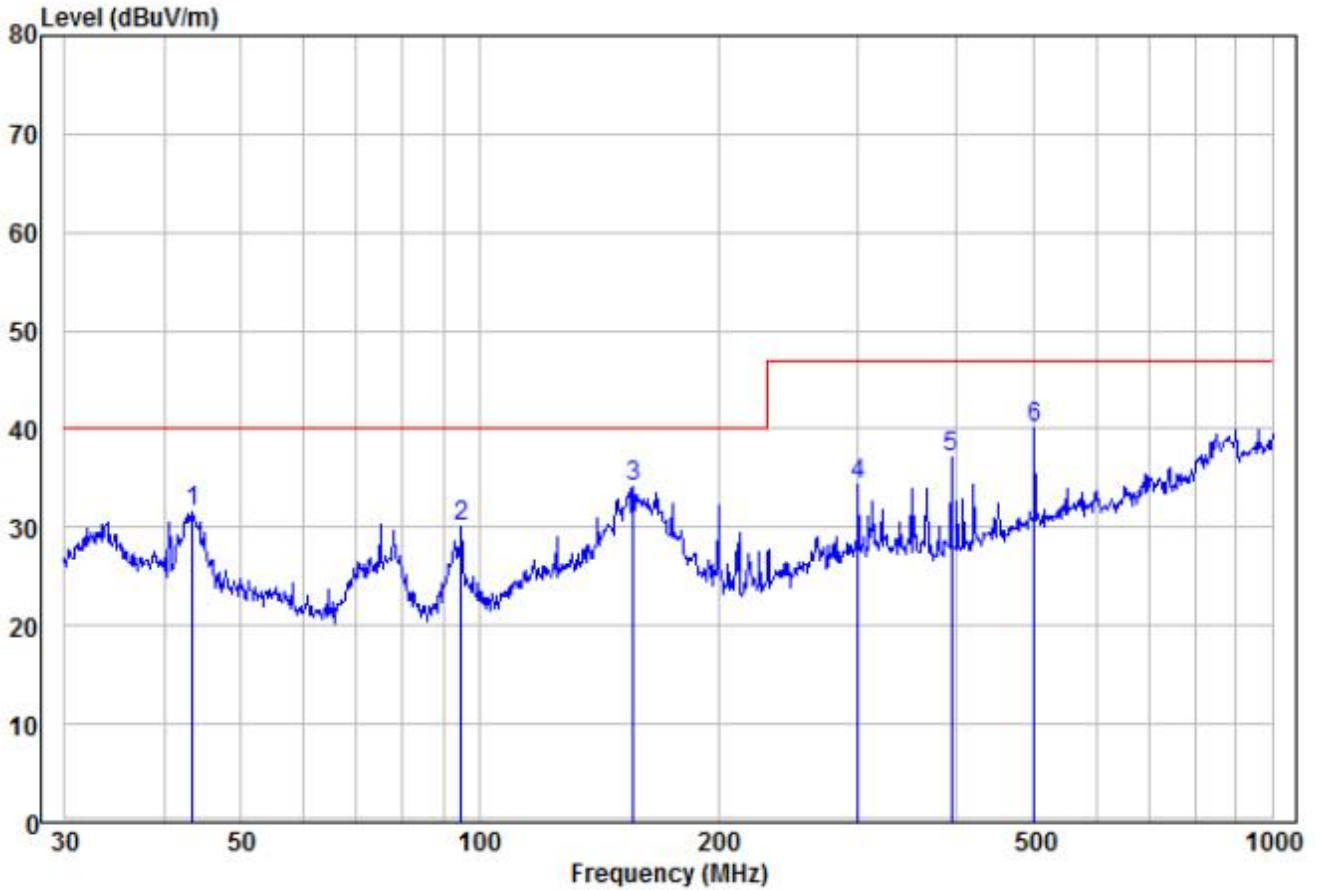

	Read Freq	Read Level	Factor	Level	Limit Line	Over Limit	Remark	Pol/Phase
	MHz	dBuV	dB/m	dBuV/m	dBuV/m	dB		
1	43.51	18.84	12.66	31.50	40.00	-8.50	Peak	VERTICAL
2	94.76	17.88	12.15	30.03	40.00	-9.97	Peak	VERTICAL
3 pp	156.46	24.07	10.11	34.18	40.00	-5.82	Peak	VERTICAL
4	300.37	16.59	17.78	34.37	47.00	-12.63	Peak	VERTICAL
5	393.47	18.18	19.03	37.21	47.00	-9.79	Peak	VERTICAL
6	501.18	18.35	21.84	40.19	47.00	-6.81	Peak	VERTICAL

Horizontal

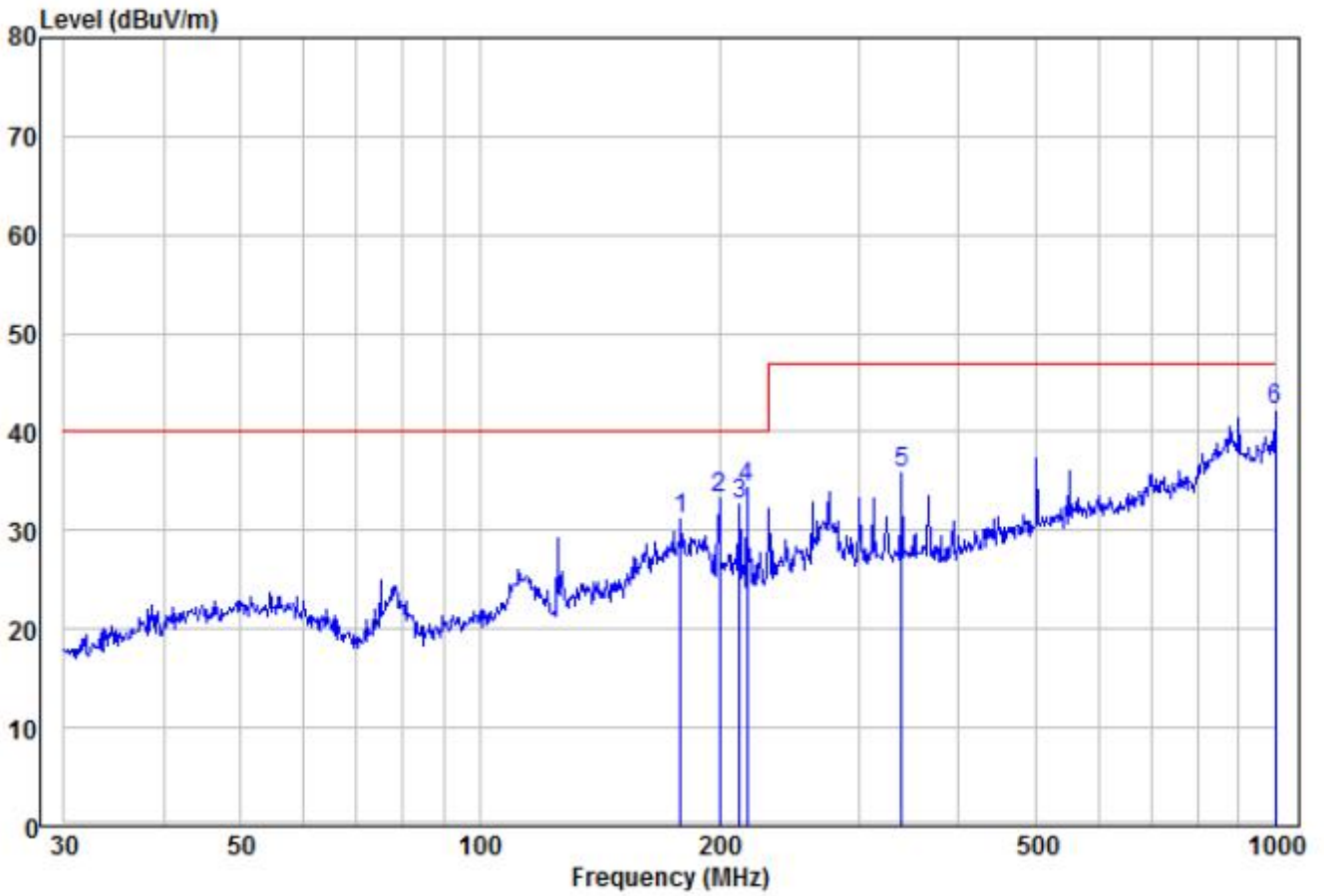

	Freq	Read Level	Factor	Level	Limit Line	Over Limit	Remark	Pol/Phase
	MHz	dBuV	dB/m	dBuV/m	dBuV/m	dB		
1	178.76	19.97	11.27	31.24	40.00	-8.76	Peak	HORIZONTAL
2	199.99	20.24	13.02	33.26	40.00	-6.74	Peak	HORIZONTAL
3	212.27	19.34	13.35	32.69	40.00	-7.31	Peak	HORIZONTAL
4	216.78	20.96	13.47	34.43	40.00	-5.57	Peak	HORIZONTAL
5	339.59	17.12	18.73	35.85	47.00	-11.15	Peak	HORIZONTAL
6 pp	1000.00	12.96	29.20	42.16	47.00	-4.84	Peak	HORIZONTAL

Above 1GHz

Class B: Above 1GHz : at 3M							
Ant.Pol.	Frequency	Measurement (dBuV)		Limit 3m(dBuV/m)		Over(dB)	
	MHz	PK	AV	PK	AV	PK	AV
Horizontal	1067.90	51.93	35.23	74	54	-22.07	-18.77
	2273.58	51.15	36.11	74	54	-22.85	-17.89
	4574.60	58.92	38.50	74	54	-15.08	-15.50
Vertical	1635.63	50.94	37.56	74	54	-23.06	-16.44
	2381.86	53.61	35.75	74	54	-20.39	-18.25
	4685.88	55.88	39.62	74	54	-18.12	-14.38

Remark: The EUT was test at 3m in field chamber.

Level = Read Level + Antenna Factor + Cable Loss – Preamp Factor.

1)Pertest the EUT at voltages of 230V and 110V, using a frequency of 50Hz or 60Hz, but find the voltages of 230V and the frequency of 50Hz which is worst case, only the data of the worst-case show in the test report.

6.1.2 Conducted Emission

1) For AC Main Port

Test Requirement: EN 301 489-17
Test Method: EN 301 489-1 Clause 8.4.2
Detector: Peak for pre-scan (9kHz Resolution Bandwidth)
 Quasi-Peak if maximized peak within 6dB of Quasi-Peak limit

EUT Operation:

Ambient: Temp.: 20.5°C Humid.: 52% Press.: 1009 mbar

Test mode: wireless mode

Equipment Used: Refer to section 5 for details.

Limit: Limits for conducted disturbance at the mains ports of class B

Frequency Range (MHz)	Class B Limit (dB μ V)	
	Quasi-peak	Average
0.15 to 0.50	66 to 56	56 to 46
0.50 to 5	56	46
5 to 30	60	50

NOTE 1: The limit decreases linearly with the logarithm of the frequency in the range 0.15 MHz to 0.50 MHz.
 NOTE 2: The lower limit is applicable at the transition frequency.

Test Setup:

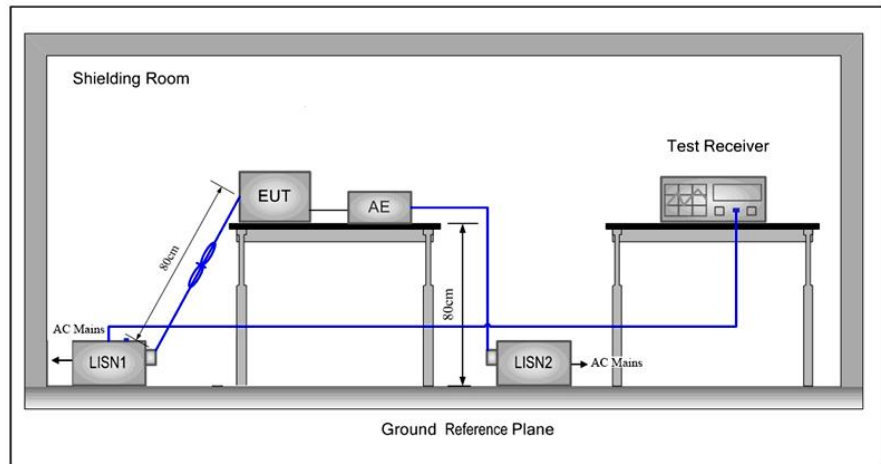

Test Procedure:

- 1) The mains terminal disturbance voltage test was conducted in a shielded room.
- 2) The EUT was connected to AC power source through a LISN 1 (Line Impedance Stabilization Network) which provides a $50\Omega/50\mu\text{H} + 5\Omega$ linear impedance. The power cables of all other units of the EUT were connected to a second LISN 2, which was bonded to the ground reference plane in the same way as the LISN 1 for the unit being measured. A multiple socket outlet strip was used to connect multiple power cables to a single LISN provided the rating of the LISN was not exceeded.
- 3) The tabletop EUT was placed upon a non-metallic table 0.8m above the ground reference plane. And for floor-standing arrangement, the EUT was placed on the horizontal ground reference plane,
- 4) The test was performed with a vertical ground reference plane. The rear of the EUT shall be 0.4 m from the vertical ground reference plane. The vertical ground reference plane was bonded to the horizontal ground reference plane. The LISN 1 was placed 0.8 m from the boundary of the unit under test and bonded to a ground reference plane for LISNs mounted on top of the ground reference plane. This distance was between the closest points of the LISN 1 and the EUT. All other units of the EUT and associated equipment was at least 0.8 m from the LISN 2.

Test result: PASS

Measurement Data:

An initial pre-scan was performed on the live and neutral lines with peak detector.

Quasi-Peak and Average measurement were performed at the frequencies with maximized peak emission were detected.

Live Line:

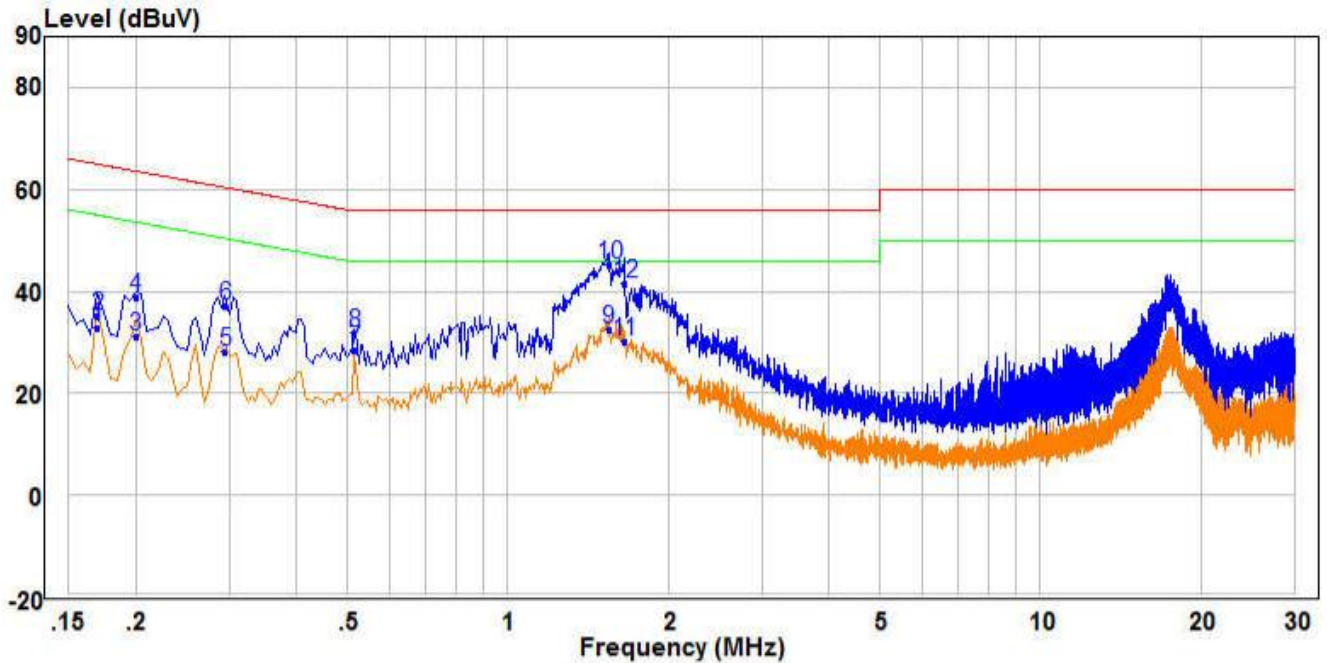

	Read Freq	Read Level	Factor	Limit Level	Over Limit	Remark	Pol/Phase	
	MHz	dBuV	dB	dBuV	dB			
1	0.170	23.20	9.66	32.86	54.96	-22.10	Average	Line
2	0.170	25.56	9.66	35.22	64.96	-29.74	QP	Line
3	0.200	21.46	9.61	31.07	53.61	-22.54	Average	Line
4	0.200	29.09	9.61	38.70	63.61	-24.91	QP	Line
5	0.295	18.71	9.50	28.21	50.38	-22.17	Average	Line
6	0.295	27.53	9.50	37.03	60.38	-23.35	QP	Line
7	0.515	18.62	9.72	28.34	46.00	-17.66	Average	Line
8	0.515	22.02	9.72	31.74	56.00	-24.26	QP	Line
9 AV	1.550	21.58	10.93	32.51	46.00	-13.49	Average	Line
10 PP	1.550	34.28	10.93	45.21	56.00	-10.79	QP	Line
11	1.655	19.10	11.11	30.21	46.00	-15.79	Average	Line
12	1.655	30.40	11.11	41.51	56.00	-14.49	QP	Line

Neutral Line:

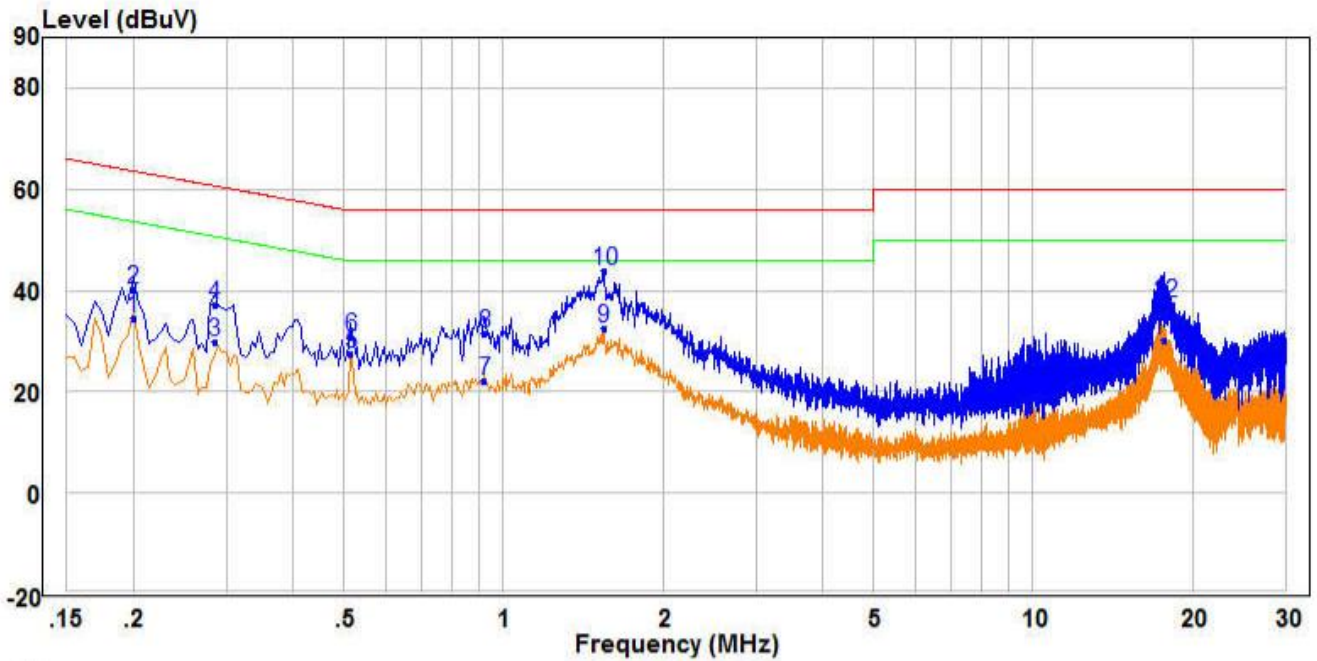

	Read Freq	Read Level	Factor	Level	Limit Line	Over Limit	Remark	Pol/Phase
	MHz	dBuV	dB	dBuV	dBuV	dB		
1	0.200	24.90	9.61	34.51	53.61	-19.10	Average	Neutral
2	0.200	30.61	9.61	40.22	63.61	-23.39	QP	Neutral
3	0.285	20.25	9.50	29.75	50.67	-20.92	Average	Neutral
4	0.285	27.65	9.50	37.15	60.67	-23.52	QP	Neutral
5	0.515	17.82	9.72	27.54	46.00	-18.46	Average	Neutral
6	0.515	21.08	9.72	30.80	56.00	-25.20	QP	Neutral
7	0.920	12.34	9.75	22.09	46.00	-23.91	Average	Neutral
8	0.920	21.81	9.75	31.56	56.00	-24.44	QP	Neutral
9 AV	1.550	22.64	9.73	32.37	46.00	-13.63	Average	Neutral
10 PP	1.550	34.25	9.73	43.98	56.00	-12.02	QP	Neutral
11	17.655	20.23	9.79	30.02	50.00	-19.98	Average	Neutral
12	17.655	27.67	9.79	37.46	60.00	-22.54	QP	Neutral

Remark:

Pretest the EUT at voltages of 230V and 110V, using a frequency of 50Hz or 60Hz, but find the voltages of 230V and the frequency of 50Hz which is worst case, only the data of the worst case show in the test report.

6.1.3 Harmonics

Test Requirement: EN 301 489-17
Test Method: EN 301 489-1 Clause 8.5

Harm#	Harms(avg)	90%Limit	%of Limit	Harms(max)	200%Limit	%of Limit	Status
2	0.008	0.972	0.9	0.014	2.160	0.6	Pass
3	0.253	2.070	12.2	1.009	4.600	21.9	Pass
4	0.009	0.387	2.3	0.016	0.860	1.8	Pass
5	0.238	1.026	23.2	0.918	2.280	40.3	Pass
6	0.009	0.270	3.2	0.016	0.600	2.7	Pass
7	0.220	0.693	31.7	0.805	1.540	52.2	Pass
8	0.009	0.207	4.2	0.016	0.460	3.6	Pass
9	0.197	0.360	54.7	0.670	0.800	83.8	Pass
10	0.008	0.166	5.0	0.016	0.368	4.3	Pass
11	0.171	0.297	57.6	0.528	0.660	79.9	Pass
12	0.008	0.138	5.7	0.014	0.306	4.5	Pass
13	0.144	0.189	76.3	0.388	0.420	92.4	Pass
14	0.007	0.118	6.1	0.013	0.262	4.8	Pass
15	0.118	0.135	87.1	0.265	0.300	88.3	Pass
16	0.006	0.104	N/A	0.011	0.230	N/A	Pass
17	0.093	0.119	78.0	0.169	0.264	64.2	Pass
18	0.006	0.092	N/A	0.009	0.204	N/A	Pass
19	0.071	0.107	66.6	0.113	0.237	47.6	Pass
20	0.005	0.083	N/A	0.007	0.184	N/A	Pass
21	0.053	0.096	55.1	0.096	0.214	44.9	Pass
22	0.004	0.075	N/A	0.007	0.167	N/A	Pass
23	0.041	0.088	46.0	0.095	0.196	48.8	Pass
24	0.003	0.069	N/A	0.006	0.153	N/A	Pass
25	0.033	0.081	41.2	0.090	0.180	49.8	Pass
26	0.003	0.064	N/A	0.005	0.142	N/A	Pass
27	0.028	0.075	37.2	0.074	0.167	44.4	Pass
28	0.003	0.059	N/A	0.005	0.132	N/A	Pass
29	0.022	0.070	31.8	0.052	0.155	33.4	Pass
30	0.002	0.055	N/A	0.004	0.123	N/A	Pass
31	0.016	0.065	24.9	0.038	0.145	26.1	Pass
32	0.002	0.052	N/A	0.004	0.115	N/A	Pass
33	0.011	0.061	17.3	0.033	0.136	23.9	Pass
34	0.002	0.049	N/A	0.003	0.108	N/A	Pass
35	0.007	0.058	12.8	0.029	0.129	22.2	Pass
36	0.001	0.046	N/A	0.003	0.102	N/A	Pass
37	0.007	0.055	13.2	0.027	0.122	22.2	Pass
38	0.001	0.044	N/A	0.002	0.097	N/A	Pass
39	0.008	0.052	14.5	0.027	0.115	23.0	Pass
40	0.001	0.041	N/A	0.002	0.092	N/A	Pass

6.1.4 Flicker

Test Requirement: EN 301 489-17

Test Method: EN 301 489-1 Clause 8.6

EUT Operation:

Ambient: Temp.: 20.5°C Humid.: 52% Press.:1009 mbar

Test mode: wireless mode, FM mode

Test status: Through Pre-scan all mode, find the wireless mode with Iphone is the worst case , So only the worst mode is recorded in the report.

Equipment Used: Refer to section 5 for details.

Test Setup:

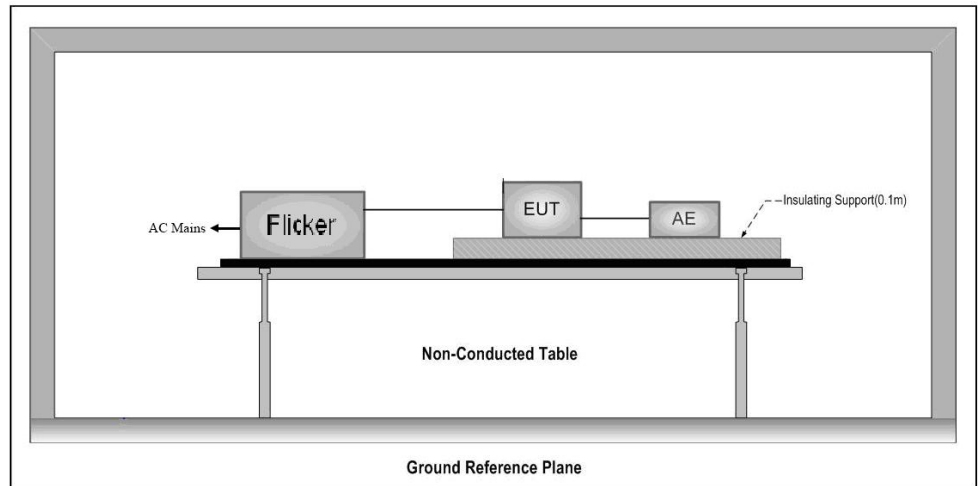

Test result: PASS

Test data:

Pst and limit line

European Limits



Plt and limit line

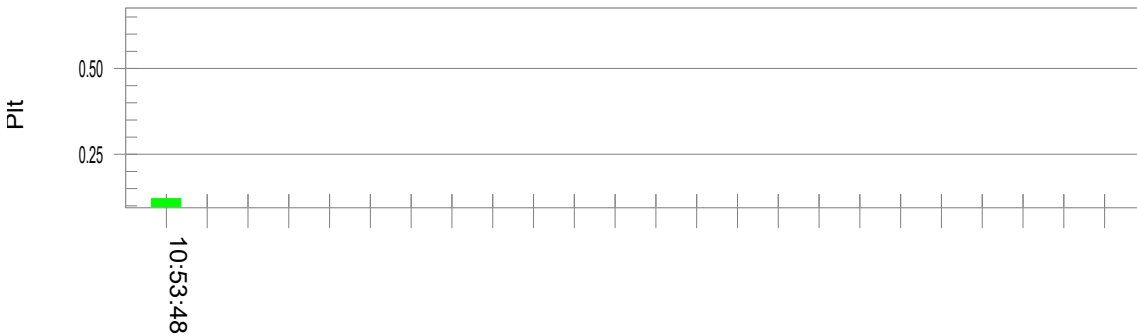

Parameter values recorded during the test:

Vrms at the end of test (Volt): 229.12
 Highest dt (%):
 T-max (mS): 0
 Highest dc (%): 0.00
 Highest dmax (%): 0.00
 Highest Pst (10 min. period): 0.288
 Highest Plt (2 hr. period): 0.121

Test limit (%):		
Test limit (mS):	500.0	Pass
Test limit (%):	3.30	Pass
Test limit (%):	4.00	Pass
Test limit:	1.000	Pass
Test limit:	0.650	Pass

6.2 EMS (Immunity)

Performance Criteria of EN 301 489-17, sub clause 6.2 table 1.

Criteria	During Test	After Test
A	Operate as intended No loss of function No unintentional responses	Operate as intended No loss of function No degradation of performance No loss of stored data or user programmable functions
B	May show loss of function No unintentional responses	Operate as intended Lost function(s) shall be self-recoverable No degradation of performance No loss of stored data or user programmable functions

6.2.1 Radiated Immunity

Test Requirement: EN 301 489-17

Test Method: EN 301 489-1 Clause 9.2.2

EUT Operation:

Ambient: Temp.: 24°C

Humid.:50%

Press.: 1009 mbar

Test mode: wireless mode

Criterion Required: A

Equipment Used: Refer to section 5 for details

Test Setup:

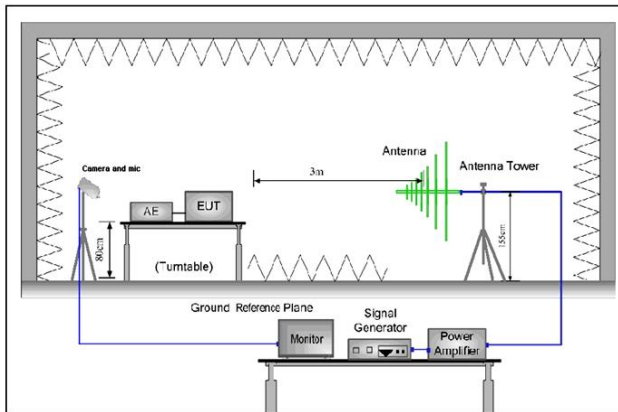

Figure 1. 80MHz to 1GHz

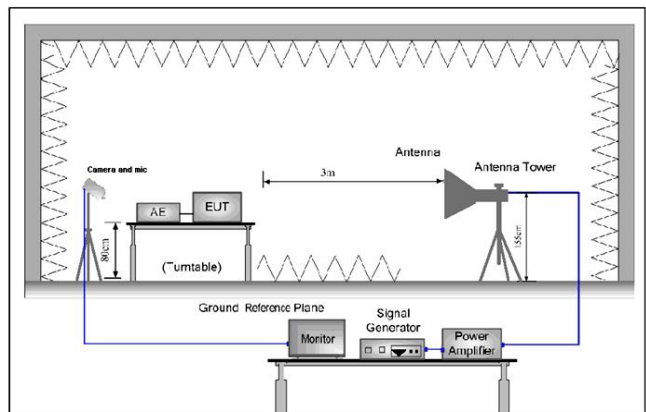

Figure 2. 1 GHz to 6GHz

Test Procedure:

- 1) For table-top equipment, the EUT was placed in the chamber on a non-conductive table 0.8m high. For arrangement of floor-standing equipment, the EUT was mounted on a non-conductive support 0.1m above the supporting plane. For human body-mounted equipment, the EUT may be tested in the same manner as table top items.
- 2) If possible, a minimum of 1 m of cable is exposed to the electromagnetic field. Excess length of cables interconnecting units of the EUT shall be bundled low-inductively in the approximate center of the cable to form a bundle 30 cm to 40 cm in length.
- 3) The EUT was initially placed with one face coincident with the calibration plane. The EUT face being illuminated was contained within the UFA (Uniform Field Area).
- 4) The frequency ranges to be considered were swept with the signal modulated and pausing to adjust the RF signal level or to switch oscillators and antennas as necessary. Where the frequency range was swept incrementally, the step size was not exceed 10 % of the preceding frequency value.
- 5) The dwell time of the amplitude modulated carrier at each frequency was not be less than the time necessary for the EUT to be exercised and to respond, and was not less than 0.5 s.
- 6) The test normally was performed with the generating antenna facing each side of the EUT.
- 7) The polarization of the field generated by each antenna necessitates testing each selected side twice, once with the antenna positioned vertically and again with the antenna positioned horizontally.
- 8) The EUT was performed in a configuration to actual installation conditions, a video camera and/or an audio monitor were used to monitor the performance of the EUT.

Test result

PASS

Test Results:

Frequency	Level	Modulation	EUT Face	Antenna Polaxis	Result / Observations
80MHz-1GHz, 1GHz to 6GHz	3V/m	1kHz, 80% Amp. Mod, 10% increment Dwell time: 3 seconds	Front	V	A
				H	A
			Back	V	A
				H	A
			Left	V	A
				H	A
			Right	V	A
				H	A
			Top	V	A
				H	A
			Under	V	A
				H	A

Remark:

A: No performance degradation during test.

6.2.2 ESD

Test Requirement:	EN 301 489-17		
Test Method:	EN 301 489-1 Clause 9.3.2		
EUT Operation:			
Ambient:	Temp.: 20.5°C	Humid.: 52%	Press.: 1009 mbar
Test mode:	wireless mode		
Criterion Required:	B		
Discharge Impedance:	330 Ω / 150 pF		
Polarity:	Positive & Negative		
Number of Discharge:	Minimum 10 times at each test point		
Discharge Mode:	Single Discharge		
Discharge Period:	1 second minimum		
Equipment Used:	Refer to section 5 for details		
Test Setup:			

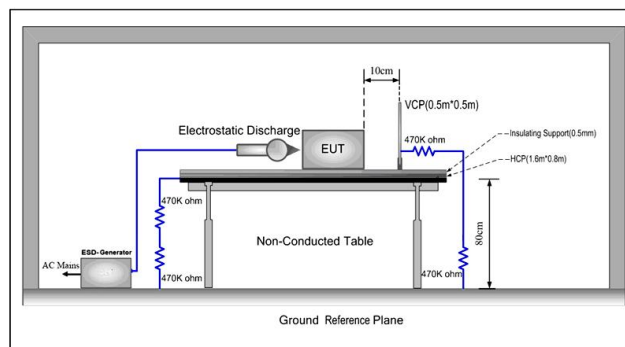

Test set-up for tabletop equipment

Test Procedure:

- 1) Contact discharges to the conductive surfaces and to coupling planes:
The EUT was exposed to at least 200 discharges, 100 each at negative and positive polarity, at a minimum of four test points (a minimum of 50 discharges at each point). One of the test points was subjected to at least 50 indirect discharges (contact) to the center of the front edge of the horizontal coupling plane. The remaining three test points shall each receive at least 50 direct contact discharges. If no direct contact test points were available, then at least 200 indirect discharges were applied in the indirect mode. Tests were performed at a maximum repetition rate of one discharge per second.
Air discharge at slots and apertures, and insulating surfaces:
On those parts of the EUT where it was not possible to perform contact discharge testing, the equipment was investigated to identify user accessible points where breakdown may occur. This investigation was restricted to those areas normally handled by the user. A minimum of 10 single air discharges were applied to the selected test point for each such area.
The application of electrostatic discharges to the contacts of open connectors was not required by this standard.
- 2) The EUT was put on a 0.8m high wooden table for table-top equipment or 0.1m high for floor standing equipment standing on the ground reference plane (GRP).
- 3) A horizontal coupling plane (HCP) 1.6m by 0.8m in size was placed on the table, and the EUT with its cables were isolated from the HCP by an insulating support thick than 0.5mm. The VCP 0.5m by 0.5m in size & HCP were constructed from the same material type & thickness as that of the GRP, and connected to the GRP via a 470kΩ resistor at each end. The distance between EUT and any of the other metallic surface excepted the GRP, HCP and VCP was greater than 1m.
- 4) During the contact discharges, the tip of the discharge electrode was touch the EUT before the discharge switch is operated. During the air discharges, the round

discharge tip of the discharge electrode was approached as fast as possible to touch the EUT.

- 5) After each discharge, the ESD generator was removed from the EUT, the generator was then retriggered for a new single discharge. For ungrounded product, a discharge cable with two resistances was used after each discharge to remove remnant electrostatic voltage. 10 times of each polarity single discharge were applied to HCP and VCP.

Test Results: PASS

Test result:

Observations: Test Point:
 1. All insulated enclosure and seams.
 2. All accessible metal parts of the enclosure.

Direct Application Test Results

Direct Application			Test Results	
Discharge Level (kV)	Pulse No.	Test Point	Contact Discharge	Air Discharge
± 2,4,8	10 for every level	1	N/A	A
± 4	10 for every level	2	A	N/A

Indirect Application for tabletop equipment Test Results

Indirect Application		Test Results	
Discharge Level (kV)	Pulse No.	Horizontal Coupling	Vertical Coupling
± 4	10 for every level	A	A

Remark:

A: No performance degradation during test.

N/A: Not applicable

6.2.3 RF Common Mode 0.15MHz to 80MHz

Test Requirement:	EN 301 489-17		
Test Method:	EN 301 489-1 Clause 9.5.2		
Test Level:	3V rms		
Modulation:	80%, 1kHz Amplitude Modulation		
Test Port :	1) AC port. 2) Telecommunication,signal,control and DC port (line longer than 3 m).		
Criterion Required:	A		
EUT Operation:			
Ambient:	Temp.:20.5°C	Humid.: 52%	Press.: 1009 mbar
Test mode:	wireless mode		
Equipment Used:	Refer to section 5 for details.		
Test Setup:			

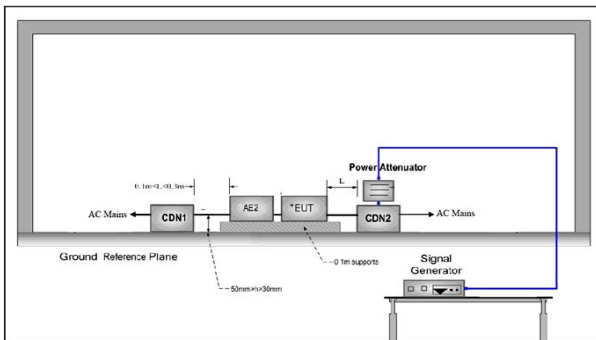

Figure 1. For AC port

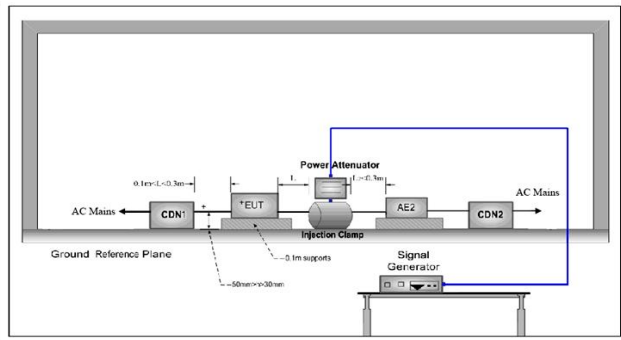

Figure2. For telecommunication, signal, control and DC port

Test Procedure:

- 1) The EUT was placed on an insulating support of 0.1m height above a ground reference Plane, arranged and connected to satisfy its functional requirement. All cables exiting the EUT was supported at a height of at least 30 mm above the ground reference plane.
- 2) The coupling and decoupling devices were required, they were located between 0.1 m and 0.3 m from the EUT. This distance was to be measured horizontally from the projection of the EUT on to the ground reference plane to the coupling and decoupling device.
- 3) Each AE, used with clamp injection, shall be placed on an insulating support 0.1 m above the ground reference plane. A decoupling network shall be installed on each cable between the EUT and AE except the cable under test. All cables connected to each AE, other than those being connected to the EUT, shall be provided with decoupling networks. The decoupling networks connected to each AE (except those on cables between the EUT and AE) shall be applied no further than 0.3 m from the AE. The cable(s) between the AE and the decoupling network (s) or in between the AE and the injection clamp shall not be bundled nor wrapped and shall be kept between 30 mm and 50 mm above the ground reference plane
- 4) The frequency range was swept from 150 kHz to 80 MHz, using the signal levels established during the setting process, and with the disturbance signal 80 % amplitude modulated with a 1 kHz sine wave, pausing to adjust the RF signal level or to change coupling devices as necessary. Where the frequency was swept incrementally, the step size does not exceed 1 % of the preceding frequency value. The dwell time of the amplitude modulated carrier at each frequency was not less than the time necessary for the EUT to be exercised and to respond, and was not less than 0.5 s.

Test result: PASS

Test Result:

Frequency	Line	Test Level	Modulation	Step Size	Dwell Time	Observation (Performance Criterion)
150kHz to 80MHz	AC port (2 Line)	3Vrms	80%, 1kHz Amp. Mod.	1%	2 S	A

Remark:

A: No performance degradation during test.

6.2.4 Electrical Fast Transients (EFT)

Test Requirement: EN 301 489-17
Test Method: EN 301 489-1 Clause 9.4.2
Test Level: 1) $\pm 0.5\text{kV}$, $\pm 1.0\text{kV}$ on AC port.
 2) $\pm 0.5\text{kV}$ on telecommunication, signal, control and DC port (line longer than 3 m).
Polarity: Positive & Negative
Repetition Frequency: 5kHz
Burst Period: 300ms
Test Duration: 2 minute per level & polarity
EUT Operation:
 Ambient: Temp.: 20.5°C Humid.: 52% Press.: 1009 mbar
 Test mode: wireless mode, FM mode
Equipment Used: Refer to section 5 for details.
Test Setup:

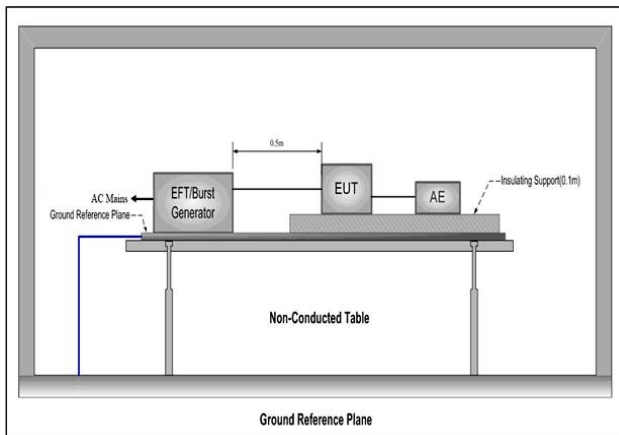

Figure 1. For AC port

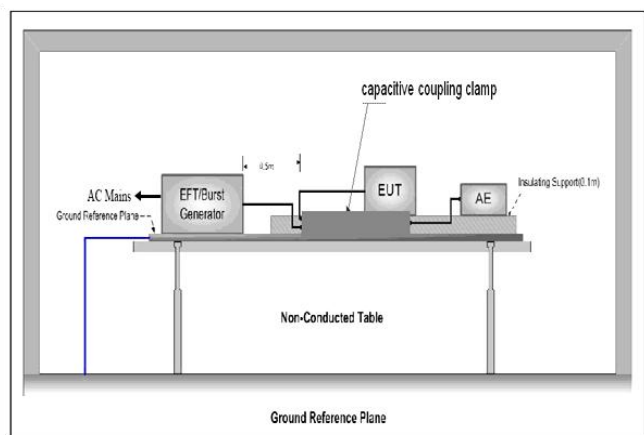

Figure2. For telecommunication, signal, control and DC port

Test Procedure:

- 1) The EUT was placed on a ground reference plane (GRP) insulated by an insulating support 0.1 m thick and the GRP was placed on a 0.8m high wooden table for table-top equipment. For floor standing equipment, the EUT was placed on a 0.1m high wooden support above the GRP.
- 2) The GRP shall project beyond the EUT and the clamp by at least 0.1m on all sides. The distance between the EUT and any other of the metallic surface except the GRP was greater than 0.5m. All cables to the EUT was placed on the insulation support 0.1m above GRP. A cable not subject to EFT was routed as far as possible from cable under test to minimize the coupling between the cables.
- 3) The length of signal and power cable between the EUT and EFT generator was 0.5m. If the cable is a non-detachable supply cable more than 0.5m, the excess length of this cable shall be folded to avoid a flat coil and situated at a distance of 0.1m above the GRP.
- 4) The EUT was conducted the below specified test voltages for line and neutral or line, neutral and earth simultaneously (for telecommunication, single, control and DC port line with capacitive coupling clamp), 120 seconds duration. If the equipment contains identical ports, only one was tested; multicomputer cables, such as a 50-pair telecommunication cable, were tested as a single cable. Cables did not be split or divided into groups of conductors for this test; interface ports, which were intended by the manufacturer to be connected to data cables not longer than 3 m, did not be tested.

Test result:

PASS

Test Results:

Lead under Test	Level (kV)	Coupling Direct/Clamp	Observations (Performance Criterion)
Live	± 0.5, 1.0	Direct	A
Neutral	± 0.5, 1.0	Direct	A
Live, Neutral	± 0.5, 1.0	Direct	A

Remark:

A: No performance degradation during test.

6.2.5 Surge

Test Requirement:	EN 301 489-17		
Test Method:	EN 301 489-1 Clause 9.8.2		
Test Level:	For AC port	For telecommunication port	
	1) $\pm 1\text{kV}$ Live to Neutral	1) $\pm 1.0\text{kV}$ line to ground (outdoor cable)	
	2) $\pm 2\text{kV}$ Live. Neutral to Earth	2) 0.5kV line to ground (indoor cable longer than 10 m)	
Criterion Required:	B		
Polarity:	Positive & Negative		
Interval:	60s between each surge		
No. of Surges:	5 positive, 5 negative at 0° , 90° , 180° , 270° .		
EUT Operation:			
Ambient:	Temp.: 20.5°C	Humid.: 52%	Press.: 1009 mbar
Test mode:	wireless mode		
Equipment Used:	Refer to section 5 for details.		
Test Setup:			

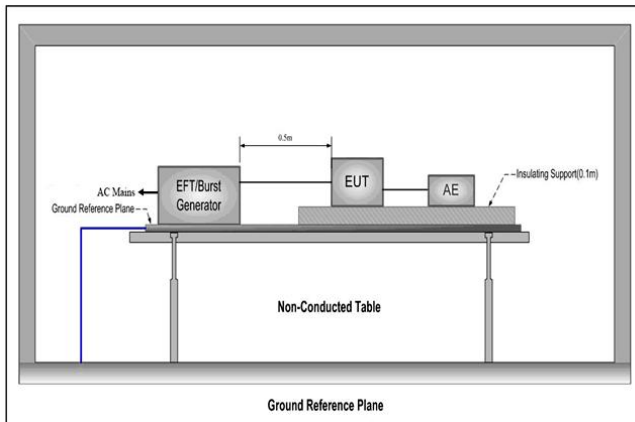

Figure 1. For AC port

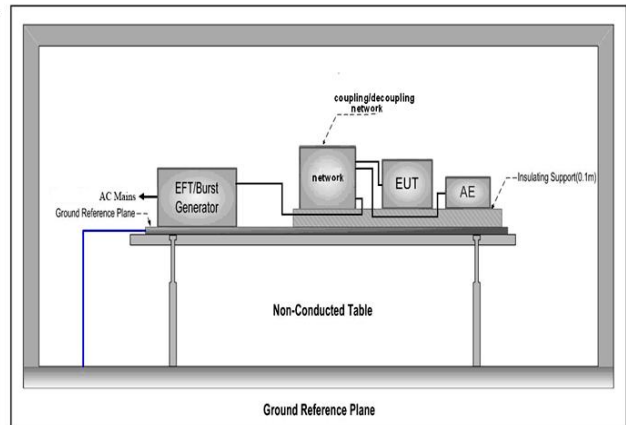

Figure2. For telecommunication port

Test Procedure:

- 1) The EUT was placed on a ground reference plane (GRP) insulated by an insulating support 0.1 m thick and the GRP was placed on a 0.8 m high wooden table for table-top equipment. For floor standing equipment, the EUT was placed on a 0.1 m high wooden support above the GRP.
- 2) The 1.2/50 μs surge was to be applied to the EUT power supply terminals via the capacitive coupling network. Decoupling networks were required in order to avoid possible adverse effects on equipment not under test that may be powered by the same lines and to provide sufficient decoupling impedance to the surge wave so that the specified wave may be applied on the lines under test.
- 3) The power cord between the EUT and the coupling/decoupling network was not exceed 2 m in length. The interconnection line between the EUT and the coupling/decoupling network shall not exceed 2 m in length.
- 4) The EUT was conducted 0.5 kV and 1 kV test voltage for line to line and line to neutral and conducted 0.5 kV, 1 kV and 2 kV test voltage for line to earth and neutral to earth, five positive pulses and five negative pulses each at 0° , 90° , 180° and 270° for a.c. power ports and five positive pulses and five negative surge pulses for d.c. power ports (for telecommunication port, it was 0.5 kV for indoor cable longer than 10 m line to ground and 0.5 kV, 1 kV test voltage for outdoor cable line to ground, five positive pulses and five negative surge pulses), The test levels were applied on the EUT with a 2Ω generator source impedance for power supply terminals and 40Ω output impedance for interconnection lines. The tests were done at repetition rate

Test result: one per minute.
PASS

Test Results:

For AC port (2 line)					
Pulse No	Line-Line	Level (kV)	Surge interval	phase (deg)	Observation (Performance Criterion)
1-5	L-N	+1	60s	0°	A
6-10	L-N	-1	60s	0°	A
11-15	L-N	+1	60s	90°	A
16-20	L-N	-1	60s	90°	A
21-25	L-N	+1	60s	180°	A
26-30	L-N	-1	60s	180°	A
31-35	L-N	+1	60s	270°	A
36-40	L-N	-1	60s	270°	A

Remark:

A: No performance degradation during test.

6.2.6 Voltage Dips and Interruptions

Test Requirement: EN 301 489-17
Test Method: EN 301 489-1 clause 9.7.2
Test Level: Voltage dip: 0 % residual voltage for 0.5 cycle;
Voltage dip: 0 % residual voltage for 1 cycle;
Voltage dip: 70 % residual voltage for 25 cycles(at 50 Hz);
Voltage interruption: 0 % residual voltage for 250 cycles(at 50 Hz).

No. of Dips / Interruptions: 3 per Level

EUT Operation:

Ambient: Temp.: 20.5°C Humid.: 52% Press.:1009 mbar

Test mode: wireless mode

Test Setup:

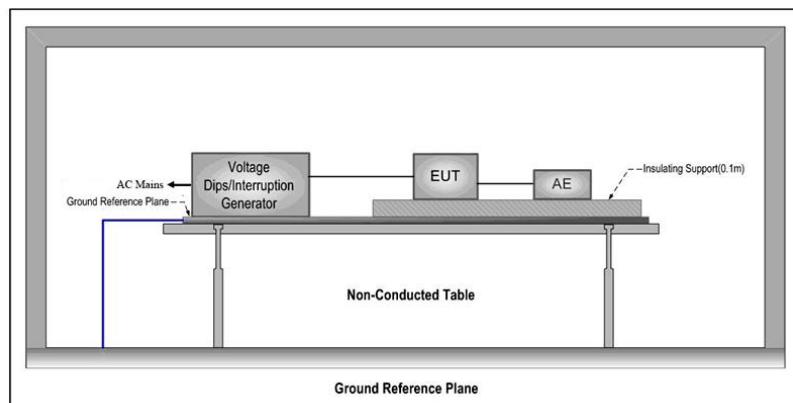

Test Procedure:

- 1) The EUT was placed on a ground reference plane(GRP) insulated by an insulating support 0.1 m thick and the GRP was placed on a 0.8m high wooden table for table-top equipment. For floor standing equipment, the EUT was placed on a 0.1m high wooden support above the GRP.
- 2) The test was performed with the EUT connected to the test generator with the shortest power supply cable as specified by the EUT manufacturer.
- 3) The EUT was tested for each selected combination of test level and duration with a sequence of three dips /interruptions with intervals of 10 s minimum. Each representative mode of operation was tested.
- 4) For EUT with more than one power cord, each power cord was tested individually.

Equipment Used:

Refer to section 5 for details.

Test result:

PASS

Test Results:

EUT operating mode	% U_T	Phase	Duration of dropout in Periods	No. of dropout	Time between dropout	Observations (Performance Criterion)
Above modes	0	0° & 180°	0.5	3	10s	A
Above modes	0	0° & 180°	1	3	10s	A
Above modes	70	0° & 180°	25	3	10s	A
Above modes	0	0° & 180°	250	3	10s	A

Remark:

A: No performance degradation during test.

APPENDIX 1 PHOTOGRAPHS OF TEST SETUP

Radiated emission Test Setup (30MHz~1GHz)



Conducted emission Test Setup

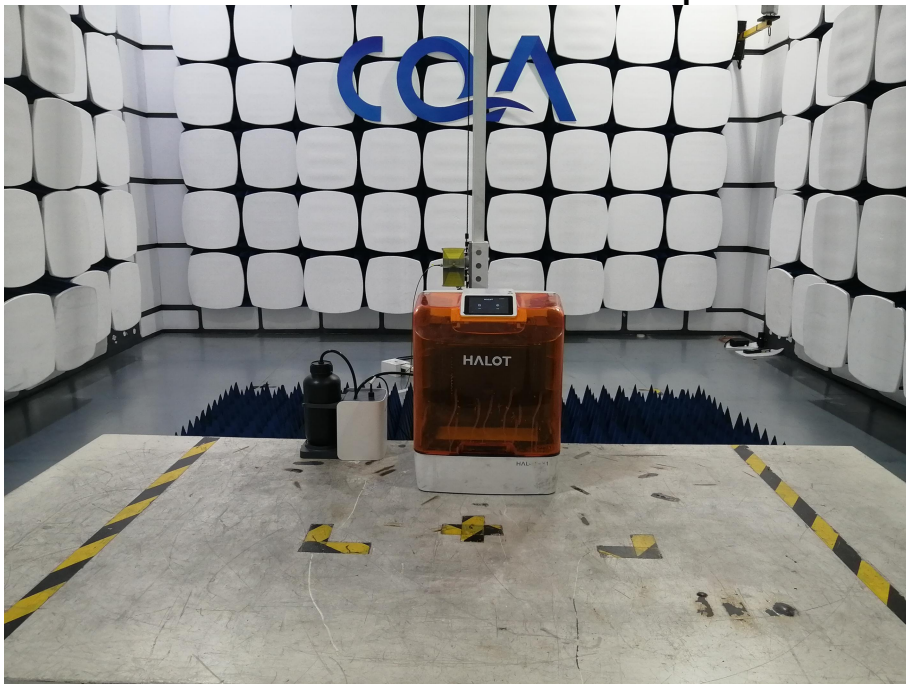

Voltage fluctuations and flicker Test Setup



Voltage dips and interruptions, EFT and Surge Test Setup

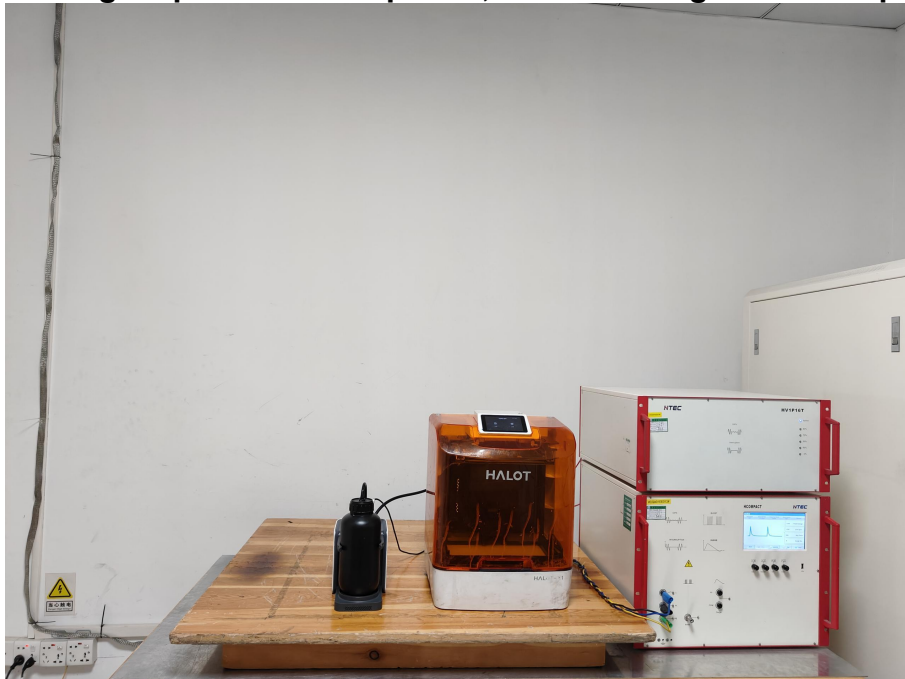

RF common mode Test Setup

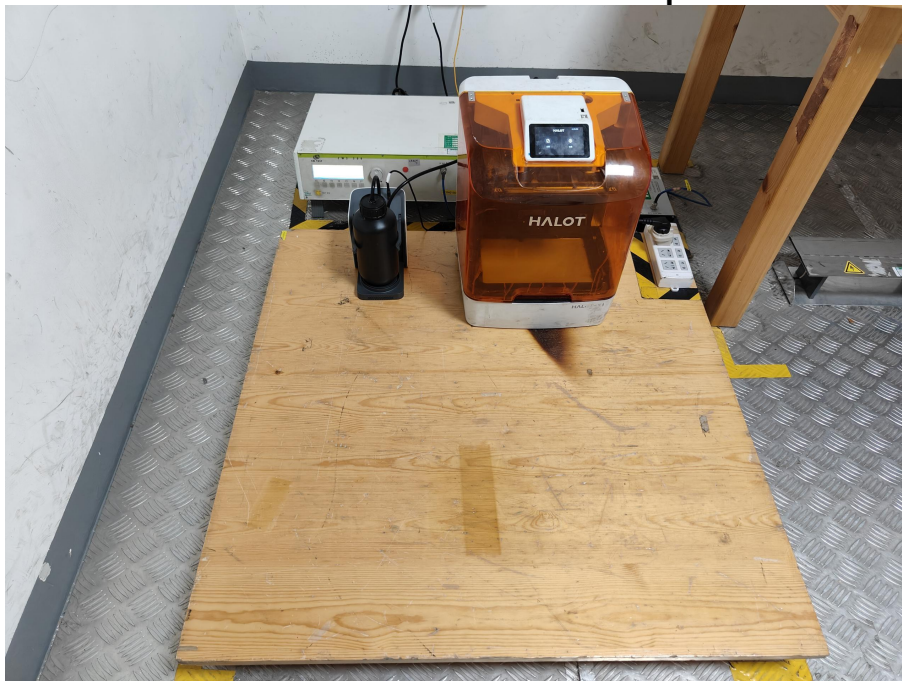

Electrostatic discharge Test Setup



APPENDIX 2 PHOTOGRAPHS OF EUT

Refer to APPENDIX 2 PHOTOGRAPHS OF EUT for CQASZ20250300702E-01.

*** END OF REPORT ***